

## EXPERIMENT 7

### NEGATIVE FEEDBACK and APPLICATIONS

#### I. PURPOSE:

To use various types of feedback with an operational amplifier. To build a gain-controlled amplifier, an integrator, and a differentiator.

#### II. THEORETICAL CONSIDERATIONS

##### II.1 FEEDBACK

In control systems, feedback consists in comparing the *output* of the system with the *desired output* and making a correction accordingly.<sup>1</sup>

##### Negative feedback

Negative feedback is the process of coupling a portion of the output back into the input, as a way to cancel part of the input.

This process, it turns out, has the effect of reducing the gain of the amplifier, but, in exchange, it improves other characteristics including freedom from distortion and nonlinearity, flatness in the frequency response, and predictability. In fact, as more negative feedback is used, the resultant amplifier's characteristics becomes less dependent on the characteristics of the original open-loop amplifier

##### Positive feedback

We have learned from our RC filter experiment that a phase lag exists between the input and output voltages, which increases as more components are added into the circuit. If a negative feedback-loop circuit were to accumulate large enough phase lag (i.e. greater than  $180^\circ$ ), then positive feedback occurs (the circuit ends up being an oscillator.)

##### II.2 The GOLDEN RULES (OPERATIONAL AMPLIFIER)

When implemented as part of a negative feedback external network, the behavior of the op amp can be predicted (for many practical purposes) based on two simple rules:<sup>2</sup>

**Rule I** The output attempts to do whatever is necessary as to produce that the external feedback brings the differential input voltage close to zero.

**Rule II** The inputs draw no current.

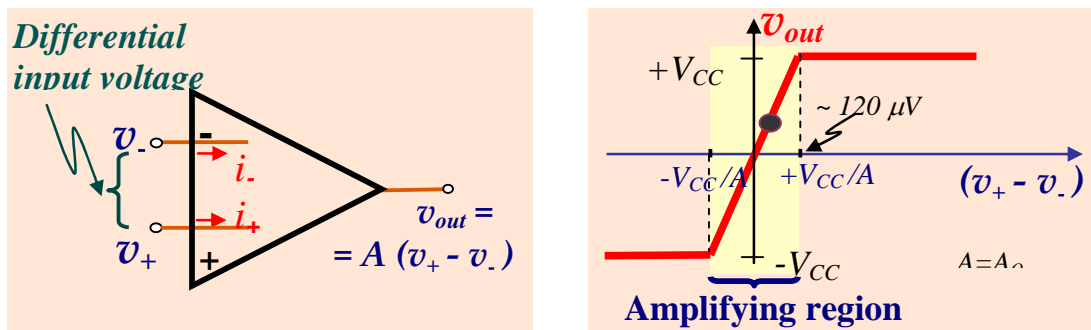

**Fig. 1** Left: Working model of an op amp. Right: Region of linear amplification of the op amp when operating in a negative feedback network.

### III. EXPERIMENTAL CONSIDERATIONS

#### Applications of negative feedback with operational amplifiers

##### III.1 The Inverting Amplifier

Since  $v_+$  is grounded, then *Rule I* implies  $v_- = 0$ . Accordingly, the current through  $R_o$  is equal to  $I_o = V_{in} / R_o$ ; and the current through  $R_f$  is then equal to  $I_f = -V_{out} / R_f$ .

Since no current flows into the op amp inputs (*Rule II*) we should have

$$I_o = I_f;$$

that is,  $V_{in} / R_o = -V_{out} / R_f$ , or simply,

$$V_{out} = -\frac{R_f}{R_o} V_{in}$$

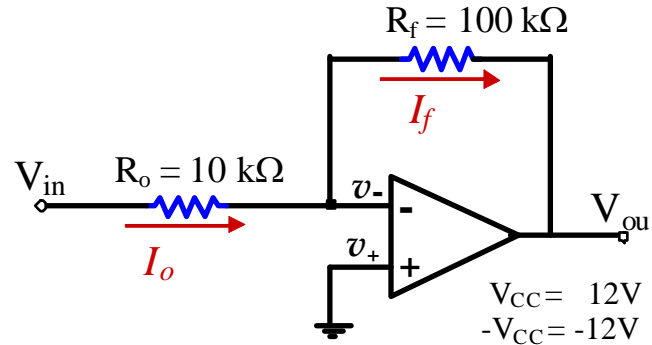

Fig. 2 DC inverted amplifier circuit.

##### Implementation:

- Construct the circuit shown in Fig. 2, and verify that indeed the voltage gain is equal to  $R_f / R_o$
- Verify that if the input signals were interchanged, the circuit will not work.

##### III.2 The Noninverting Amplifier

*Rule I* implies  $v_- = V_{in}$

At the same time,  $v_-$  is part of a voltage divider:  $v_- = [V_{out} / (R_1 + R_2)] R_1$

Equating these two expressions, we obtain,

$$V_{out} = \left[ 1 + \frac{R_2}{R_1} \right] V_{in}$$

##### Implementation:

- Construct the circuit shown in Fig. 3, whose input is a DC voltage, and verify that the voltage gain is indeed equal to  $1 + (R_2 / R_1)$ .
- Construct the circuit shown in Fig. 4, whose input is an ac signal. Notice the high-pass filter has been added. Choose  $R$  such that the 3dB point frequency of the high-pass filter is 40 Hz.

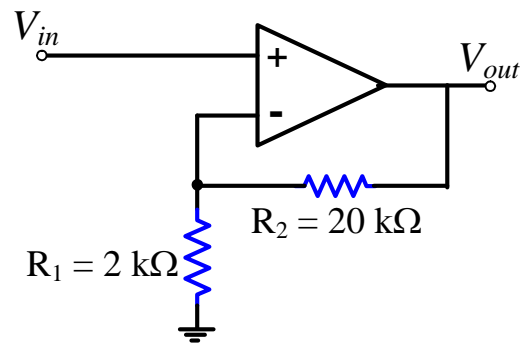
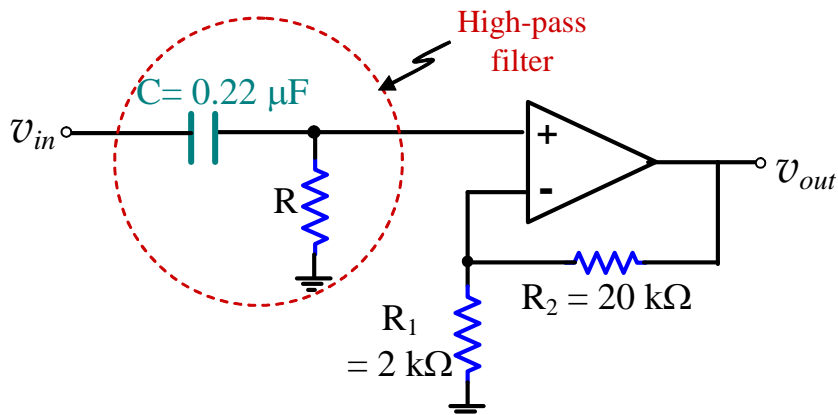

Fig. 3 Noninverting amplifier.

Make a Bode plot of the output voltage vs frequency.



**Fig. 4** Noninverting amplifier with a high-pass filter at the input.

### III.3 Differential Amplifier

#### Implementation:

a) Apply the golden rules to demonstrate that the output voltage of the circuit shown in Fig. 5 is

given by,  $V_{out} = \frac{R_2}{R_1} (V_2 - V_1)$ .

b) Build the circuit shown in Fig. 5 and verify if the output voltage varies according to the expression given in part a) above.

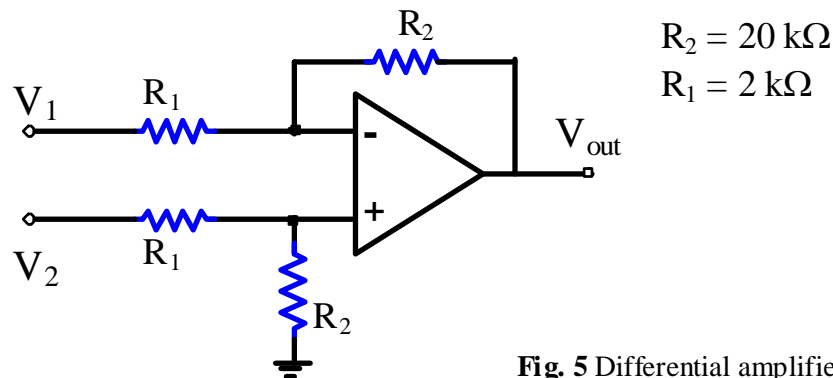

**Fig. 5** Differential amplifier.

### III.4 Integrator

Op amps allow to make integrators without the restriction that  $V_{out} < V_{out}$  (as required when using only R and C components.)

Since  $v_+$  is grounded, the input  $v_-$  acts as a virtual ground. The current  $I_R$  passing through the resistor is then given by,

$$I_R = V_{in}/R$$

The current through the capacitor is given by,

$$I_C = \frac{d}{dt}(q) = \frac{d}{dt}(0 - V_{out})C$$

$$= -C \frac{dV_{out}}{dt}$$

Rule II implies that  $I_R = I_C$ ,

$$\frac{V_{in}}{R} = -C \frac{dV_{out}}{dt}$$

This implies,

$$V_{out}(t) = -\frac{1}{RC} \int^t V_{int}(t') dt'$$

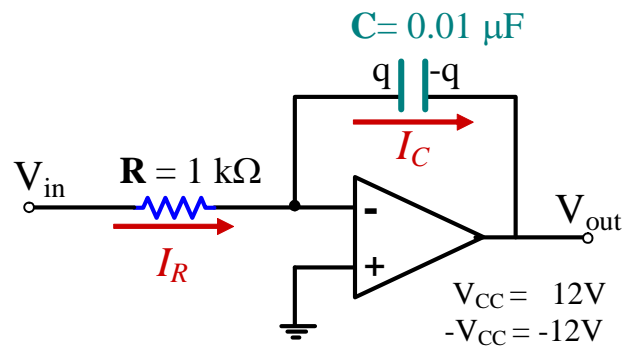

Fig. 6 Integrator.

### Implementation:

- Implement an integrator circuit (Fig.6). Since charging effects can cause serious offsets, a parallel resistor  $R_p$  may be needed (to prevent any long term voltage shift at the input). Try different values for  $R_p$ . (100KΩ, 1 MΩ). See Fig. 7.
- Test your circuit using a square signal of 1 kHz at the input. Investigate the effect of changing the various parameters.

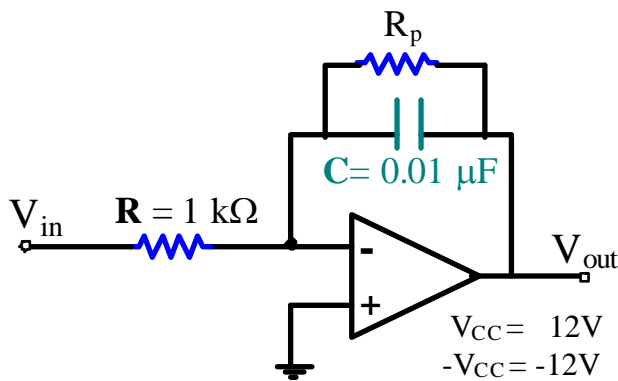

Fig. 7 Integrator.

## III.5 Differentiator

The circuitry is similar to the integrator but with the R and C reversed.

The current through the capacitor is given by,

$$I_C = \frac{d}{dt}(q) = \frac{d}{dt}(V_{int} C)$$

$$= C \frac{dV_{in}}{dt}$$

The current through the resistor is given by,

$$I_R = (0 - V_{out})/R$$

Rule II implies that  $I_R = I_C$ ,

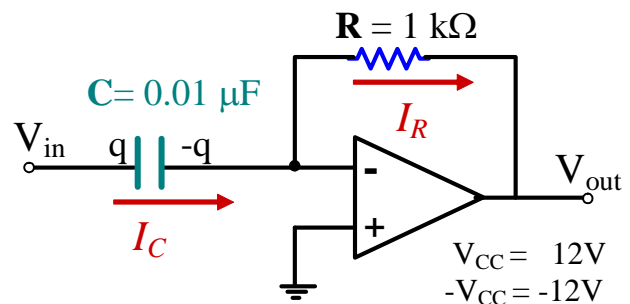

Fig. 8 Differentiator

$$C \frac{dV_{in}}{dt} = -\frac{V_{out}}{R}$$

This implies,

$$V_{out}(t) = -RC \frac{dV_{in}}{dt}$$

**Implementation:**

a) Implement an differentiator circuit. Test the circuit with triangle waves at the input.

---

<sup>1</sup> (Chapter 4) Horowitz and Hills, "The Art of Electronics." 2<sup>nd</sup> Ed.; Cambridge University Press (1990).

<sup>2</sup> (Page 177) Horowitz and Hills,