

EXPERIMENT 8 VOLTAGE-CONTROLLED OSCILLATOR

1. PURPOSE:

An integrator and a Schmitt Trigger circuitry will be put together to build a device whose output frequency can be controlled with an input voltage; hence its name “voltage-controlled oscillator.”

2. VOLTAGE-CONTROLLED OSCILLATOR

Figure 1 shows the different components of the device, broken down into three main sections to facilitate its analysis.

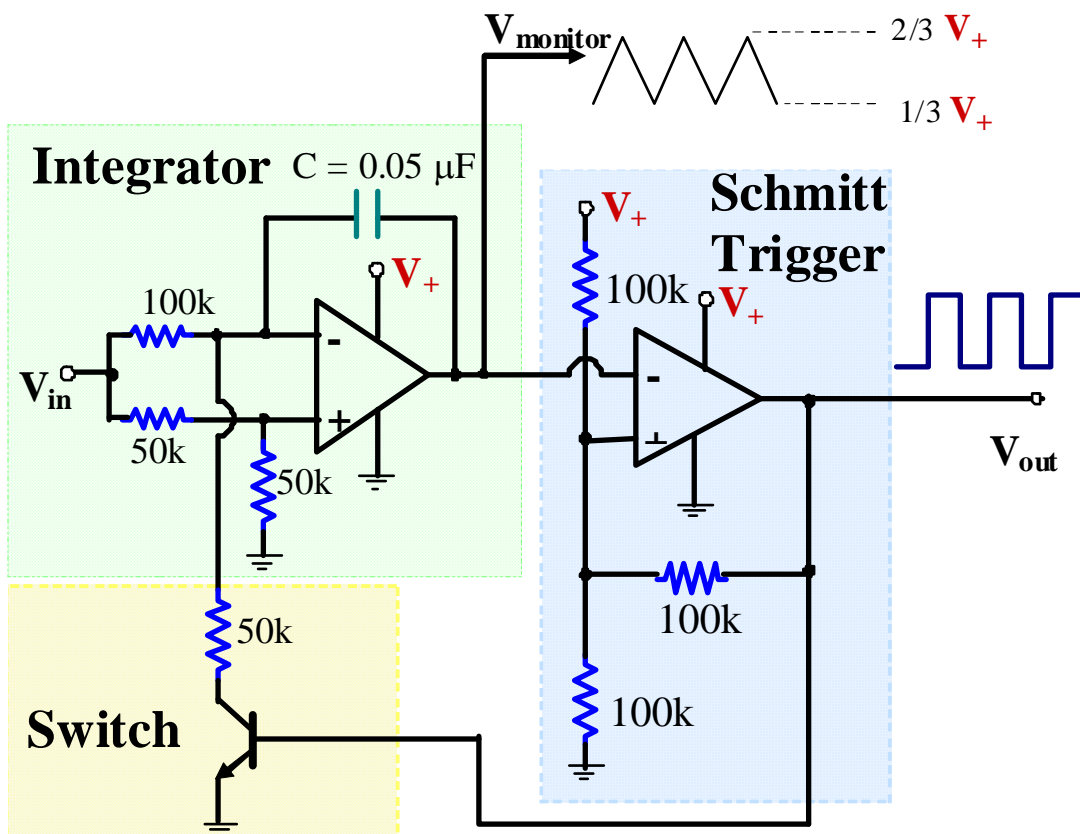

Fig.1 Device to control the frequency of the output voltage.

TASKS:

- i) Analyze the Schmitt Trigger first. Make a diagram of the expected hysteresis curve behavior.
- ii) Analyze how the Schmitt Trigger control the switch section (the transistor).
- iii) For the two cases (switch off and switch on) analyze the behavior of the integrator.

Based on the above analysis, estimate the time-period at which the output voltage changes states.

Highlight the variables this period depends on. According to this analysis, adjust the proper values of the different component in order to have a clear measurable variation of the period as the DC input voltage varies.

Hence, measure how much the frequency of the output voltage changes as a function of V_{in} (for various values of C.) In addition to C, feel free to change the value of other components.