

OPERATIONAL AMPLIFIERS

1. THE ROLE OF OPERATIONAL AMPLIFIERS

A typical digital data acquisition system uses a transducer (sensor) to convert a physical property measurement (piezoelectric, optical, or temperature response) into an electrical signal (voltage, or current). The signal level from the sensors' output, however, are typically very low (micro or nano volts) and, thus, not suitable for direct input into a computer or microcontroller (volts). A conditioning circuit composed of operational amplifiers is then use for that purpose (see diagram below.) Very important, the amplifier should be placed as close as possible to the sensor in order to minimize the amplification of noise picked-up by an otherwise long cable.

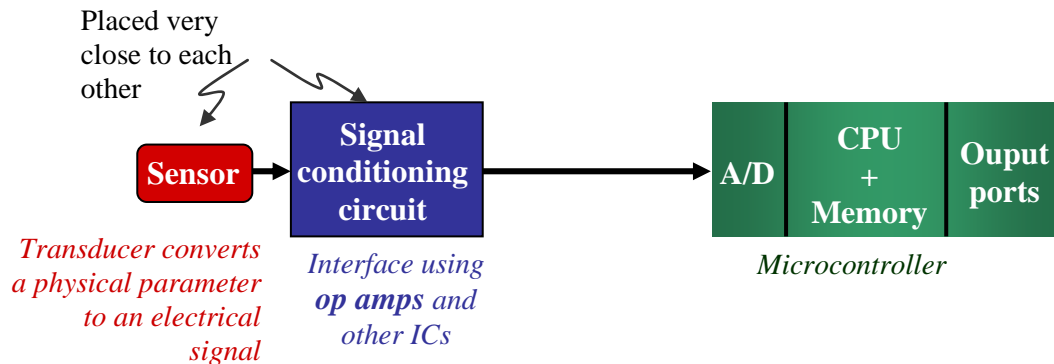

Fig. 1 Operational amplifiers in a typical data acquisition system.

2. ABOUT OPERATIONAL AMPLIFIERS

Operational amplifiers, or op-amps, form the **basic building blocks of analog electronic circuits**, much as NOR and NAND gates provide the building blocks of digital circuits. They are widely used to amplify dc or ac signals.

2.1 Differential input

In a circuit board layout, a triangle represents an op-amp (see Fig. 2.) Notice its differential input-voltage feature.

$$v_{out} = A_{OL}(v_{in(+)} - v_{in(-)}) \quad (1)$$

A_{OL} is referred to as the **open loop voltage gain**.

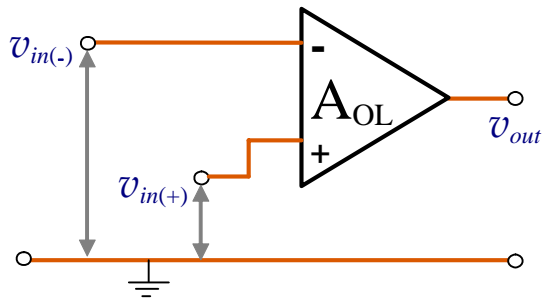

Fig.. 2 Typical representation of an op amp, displaying the differential input voltage as a distinct feature.

2.2 Terminals connections

Op amps come in a variety of packages. Figure 3 shows the pin terminals for the particular LM358AP op amp that we will use in this lab session.

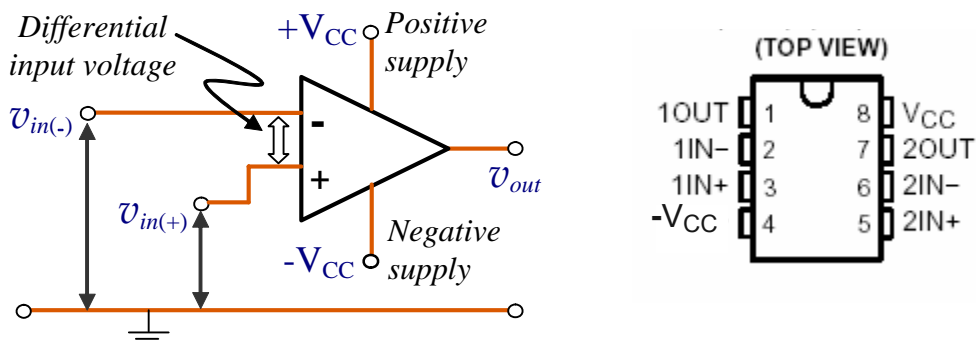

Fig. 3 **Left:** Op-amp terminals. **Right:** Pin assignment for the dual op-amp LM358AP. We will use $V_{CC} = 12$ Volts.

2.3 Open loop gain voltage A_{OL}

As indicated in expression (1) above, an operational amplifier is characteristic for producing an output voltage

v_{out} proportional to the difference of the two input voltage $v_{in(+)}$ and $v_{in(-)}$. The proportionality factor is called the **open loop voltage gain** of the amplifier.

In actuality depends on the frequency of the input signals,

$$A_{OL} = A_{OL}(\omega)$$

A_{OL} remains fairly constant (on a Bode plot) only over a limited low frequency range see also

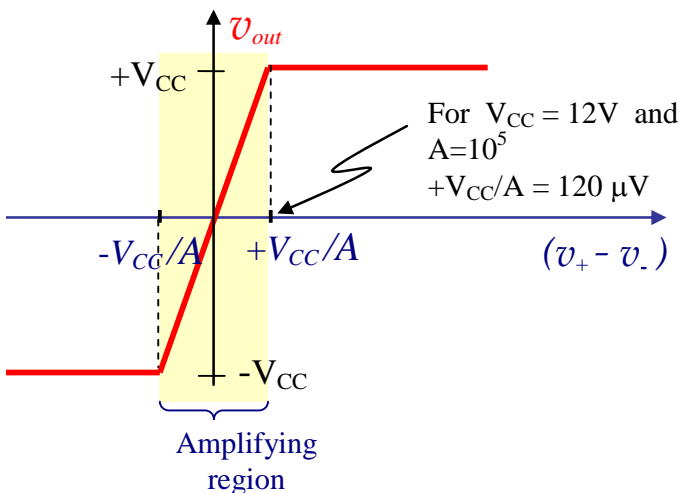

Fig. 4 Output vs input voltages.

Fig. 5 below.

2.4 How fast does an op amp respond?

2.4.A Gain-bandwidth product

The output voltage changes in response to differences in the input voltages according to,

$$\frac{dv_{out}}{dt} = \omega_T (v_{in(+)} - v_{in(-)}) \quad (3)$$

where $f_T \equiv \omega_T / 2\pi$ is the **gain-bandwidth product** of the amplifier.¹

Typical values of f_T are 0.7 MHz (LM358AP), 8 MHz (OP27), 63 MHz (OP37).

The parameter f_T can be identified in the gain-frequency bode plot as the frequency at which the gain is 1 (*i.e.* zero dB). A particularly simple voltage gain vs frequency is presented in Fig. 5.

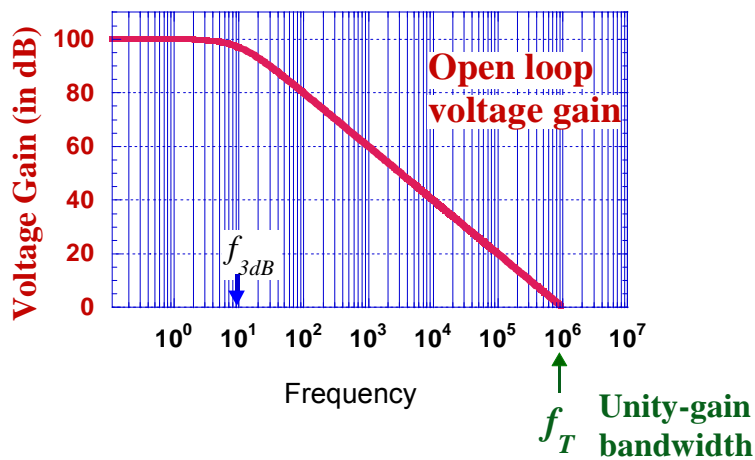

Fig.5 Particular simple open-loop voltage gain vs frequency. It displays a 1 MHz unity gain bandwidth.

2.4.B Slew rate²

The slew rate is another parameter used to characterize the speed response of an op amp. It depends on many factors: the amplifier gain, compensating capacitors, and even whether the output voltage is going positive or negative.³

The slew rate will lowest at the “unity gain” (0.3 V/μs for the LM358AP), increasing to ~ 30 times for x100 gain.

A variety of op amp offer different slew rate values: 15 V/ μ s (411), 100 V/ μ s (high speed op amps); even 6000 V/ μ s ! (LH0063C)

Because of the limited slew rate, the maximum undistorted sine-wave output swing drops above a certain frequency. A sine-wave of frequency f hertz and amplitude A volts requires a slew rate of at least $2\pi fA$.

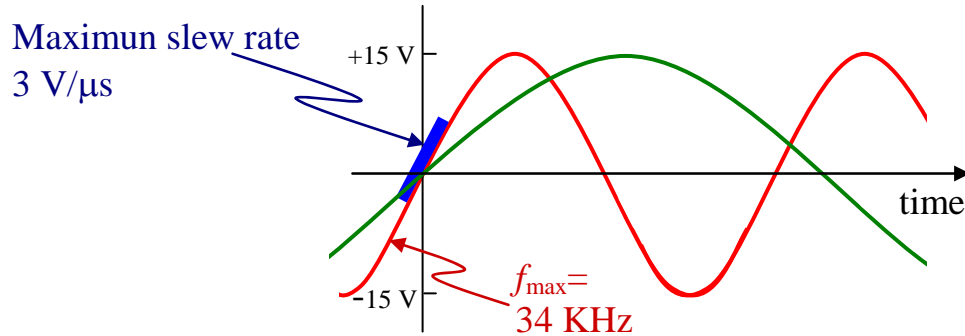

Fig. 6 Limited maximum input frequency imposed by the slew rate

Fig. 6 helps explain the output voltage swing vs frequency displayed in Fig. 7.

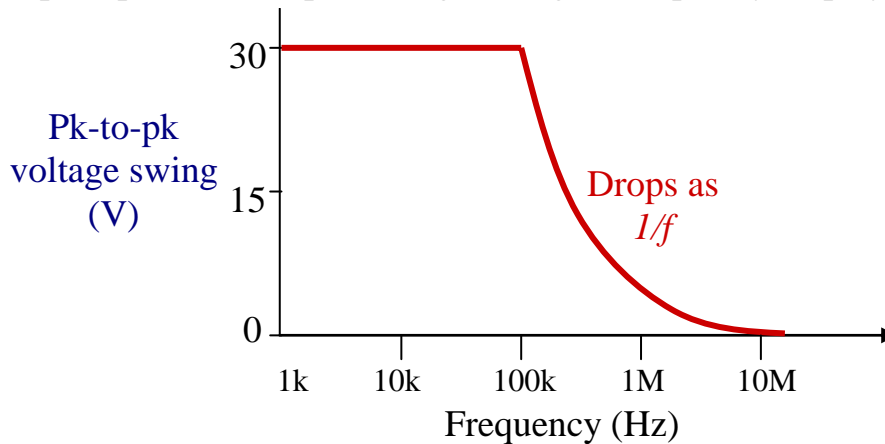

Fig. 7 Output swing vs frequency (LF411, 15 V/ μ s slew rate).

2.5 What is there inside an op amp?

A typical op-amp is an amplifier containing dozens or transistors, diodes, resistors and capacitors (see Fig. 8). Originally, they contained only bi-polar transistors, but nowadays some use field-effect transistors. By comparison,

the latter draws vary little current from the inputs during the operation of the device.

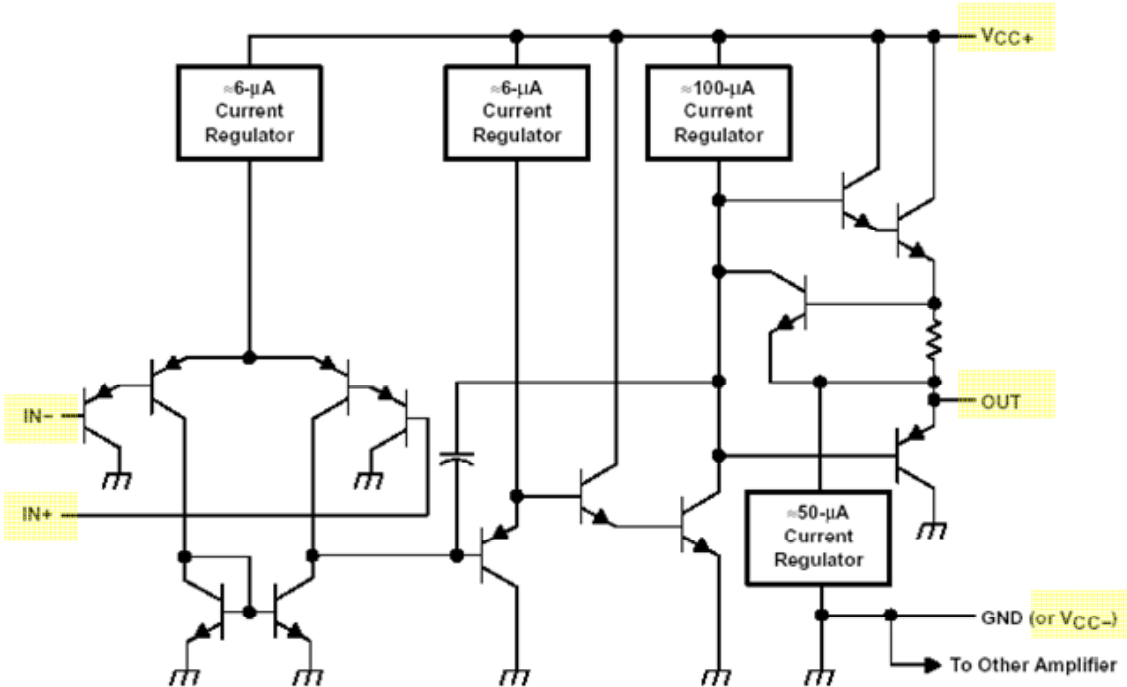

Fig. 8 Block diagram of the LM358AP op-amp

3. OP AMP MODEL

Given the high input-impedance and low output-impedance of the op amp, the diagram displayed in Fig. 9 is typically used as a working model to characterize its functioning.

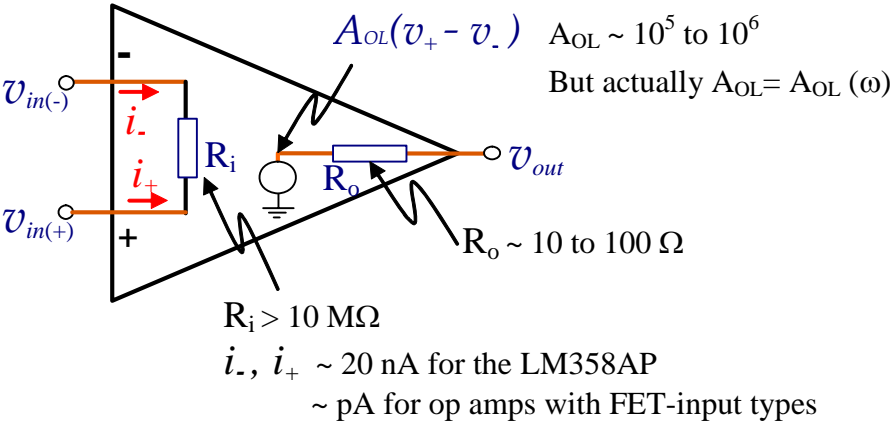

Fig. 9 Op-amp model.⁴

Fig. 9 also shows schematically *input bias currents* i_+ and i_- that the op amp draws from the input terminals $v_{in(+)}$ and $v_{in(-)}$, respectively. These

currents help to provide the proper biasing voltages that the internal transistors (see Fig. 8) need to operate properly under static or dynamic conditions.

The order of magnitude of the input bias currents range from μA (general purpose op amps), $\sim 20 \text{ nA}$ for the LM358AP, to pA or less for op amps with FET at the input. The input bias currents i_+ and i_- are usually not equal. (Once you buy a op amp, you will try to design a circuit as symmetric as possible as to make these input currents as small as possible. This is obtained, for example, by making the impedance from each input terminal to ground equal.) The difference of their magnitudes, $|i_+|$ and $|i_-|$, is called the *input offset current*. ($\sim 2 \text{ nA}$ for the LM358AP.)

In preparation ...

4. GAIN and PHASE SHIFT vs FREQUENCY

5. FEEDBACK AMPLIFIER FREQUENCY COMPENSATION

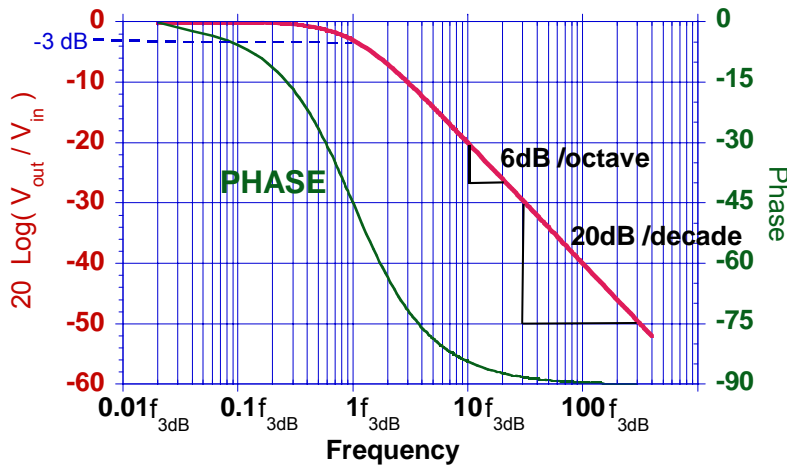

¹ (Page 5). Chapter 1 “Electronics Design of the Patch Clamp” by F. J. Sigworth; in B. Sakmann and E. Neher, Editors “Single Channel Recording, Editors; Plenum Press 1983.

² (Page 192). Horowitz and Hill, 2nd Ed.

³ (Page 285). R. F. Coughlin and F. F. Driscoll, “Operational Amplifiers and Linear Integrated Circuits,” 6th Ed. Prentice Hall, 2001.

⁴ (Page 246). J. R. Cogdell, “Foundations of Electronics,” Prentice Hall